



Your Water. Perfected.

Let us

Perfect  
your water and

Protect  
your family.

# ETF2300SC10

ECOWATER UPFLOW CHLORINE TASTE AND ODOR FILTER



Back of System

## Environmental Choice for Water Treatment

### Coconut-Shell Carbon

Filters the water throughout the home without compromising water flow. Removes chlorine taste and odor and eliminates the need for separate carbon filter changes.

### Up-flow Design

Up-flow service simplifies product design and operation (less service required).

### By-pass Valve

Allows for easy maintenance and servicing.

### Multi-Wrap Fiberglass Reinforced Tank with Limited Lifetime Warranty

Durable; doesn't deteriorate, rust, or corrode.

### Distributors

Distributors exhibit excellent flow rates.

### No Electricity

Simplifies installation, maintenance and reduces electrical hazards.

### No Salt or Added Chemicals Needed

Uses environmentally friendly "green" technology for areas with water or brine-discharge restrictions.

### Zero Waste Water

No backwashing required and zero discharge.

### Standard Plumbing Connection

1" NPT Male connection for easy installation. Larger 1-1/4" and 1-1/2" plumbing adapters available.

 Designed, Engineered & Assembled in the U.S.A.

[ecowater.com](http://ecowater.com)

# ETF2300SC10

ECOWATER UPFLOW CHLORINE  
TASTE AND ODOR FILTER

## DIMENSIONS

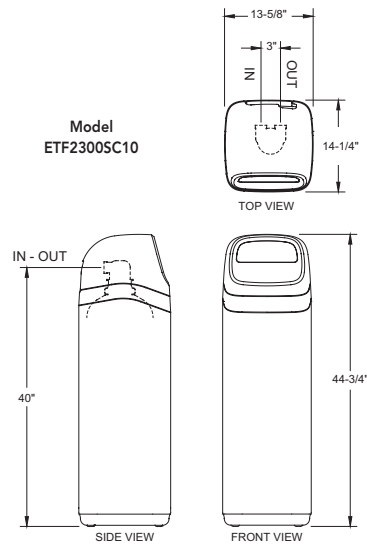

## SPECIFICATIONS

	ETF2300SC10
Nominal Mineral Tank Size	10" dia. x 35" tall
Service Flow Rate	10 gpm
Intermittent Flow Rate @ 15 psi Pressure Drop*	20 gpm
Coconut Shell Carbon	14 lbs.
HDPE	3 lbs.
Maximum Working Pressure (psi)	125
Water Temperature Limits (°F/°C)	40-120 / 4-49

\* Intermittent flow rate does not represent the maximum service flow rate. Continuous operation at flow rates greater than the service flow rate may affect performance.



Your Water. Perfected.

